

# Integrated Long Island MARKAL Model for Energy Security & Environmental Sustainability

## Energy, Water and Solid Waste Systems Analysis



US MARKAL-TIMES Symposium  
September 28-29, 2009

Vatsal Bhatt\*, John Lee\* and Edward Linky\*\*

\* Brookhaven National Laboratory

\*\* US Environmental Protection Agency, Region 2



# Urban Energy Systems Analysis

---

- ❑ Globalizing urban areas consume **75%** of the world energy
- ❑ **More than half of the world population** reside in cities (> 50 million people added each year)
- ❑ Urban energy systems are comprised of **highly complex** and **interconnected subsystems**

**MARKAL** (MARKet ALlocation) is an **integrated** energy, environment and economic methodology, to **examine market potential** for energy technologies over a short-, medium- and long-term horizon under **alternative policy scenarios**

- ❑ Utilizes a bottom-up approach to represent and characterize **technology specific portfolios** – highlights **synergies, offsets (fuel switch) and feedback effects**
- ❑ Facilitates urban Planners in selecting **cost effective technology mix** over the entire system based on **life cycle accounting**
  - Involve all **relevant stakeholders** in the planning process
  - Set-up a plan for **continuous improvement and monitoring**

# Integrated Strategic Decision Making

---

- Energy, water, waste water and solid waste are **highly interdependent complex systems**
- MARKAL provides **comprehensive and integrated** long-term infrastructure investment decisions methodology (2005-2050)
  - Identifies the **most cost-effective** pattern of **technology deployment and resource use** (e.g. energy efficient or clean energy techs), including **tradeoffs and fuel switching** (e.g. Alternative Fuels, Carbon Pricing)
  - Guides investment decisions based on **technology and investment additionality** of competing alternatives (e.g. renewable technologies or EPA Clean Water Revolving Fund decisions)
  - Assesses **long-term economic and environmental benefits and measurable payouts** of infrastructure decisions (e.g. County, City, Investment banking or Insurance industry decisions based on risk, adaptation and mitigation benefits or Socially Responsible Investment Pools)
  - Evaluates impacts of **environmental, technological and policy** restrictions on current and future decisions (e.g. carbon reduction or vehicle efficiency/cleaner standards)

# Long Island MARKAL Highlights

---

- Detailed electricity supply-demand system to simulate existing and project future electricity market on Long Island:
  - Explicit **power plant by power plant representation** of the region's electricity generators
  - Disaggregated electricity **demands (current and projected) by sector and detailed characterization of demand devices** to meet these demands
  - Explicit representation of **sources and potentials of electricity and power import** from outside of the island
  - Integrated environmental accounting functions to continuously **quantify emissions of carbon and criteria pollutants** from each energy conversion (e.g. power generation)
- Comprehensive energy/material flow and transformation of **municipal solid waste for diverse fuel applications**
- Interconnected water, waste water treatment, methane production, and electricity generation/use

# Long Island MARKAL RES

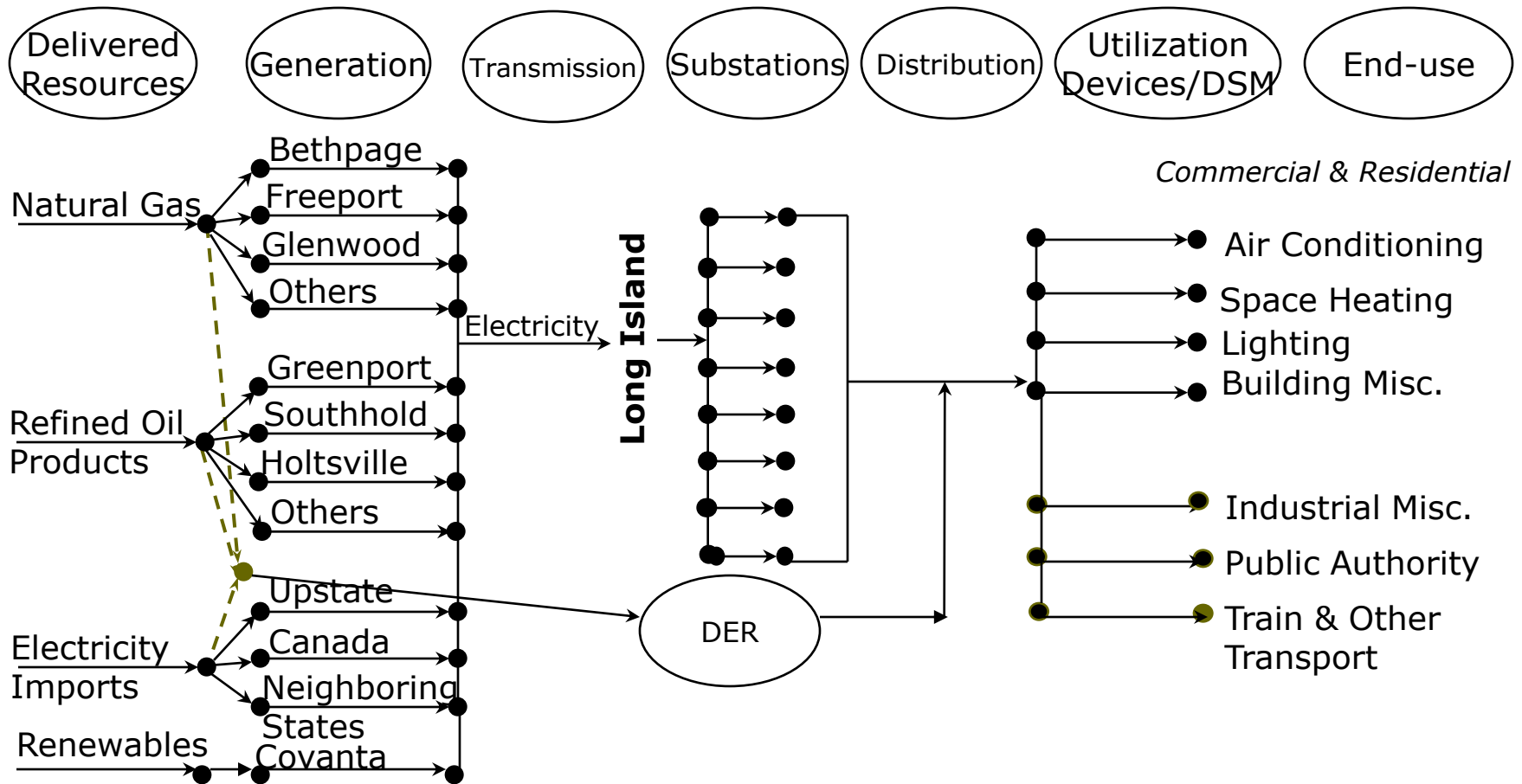

# MSW Modeled in LI MARKAL

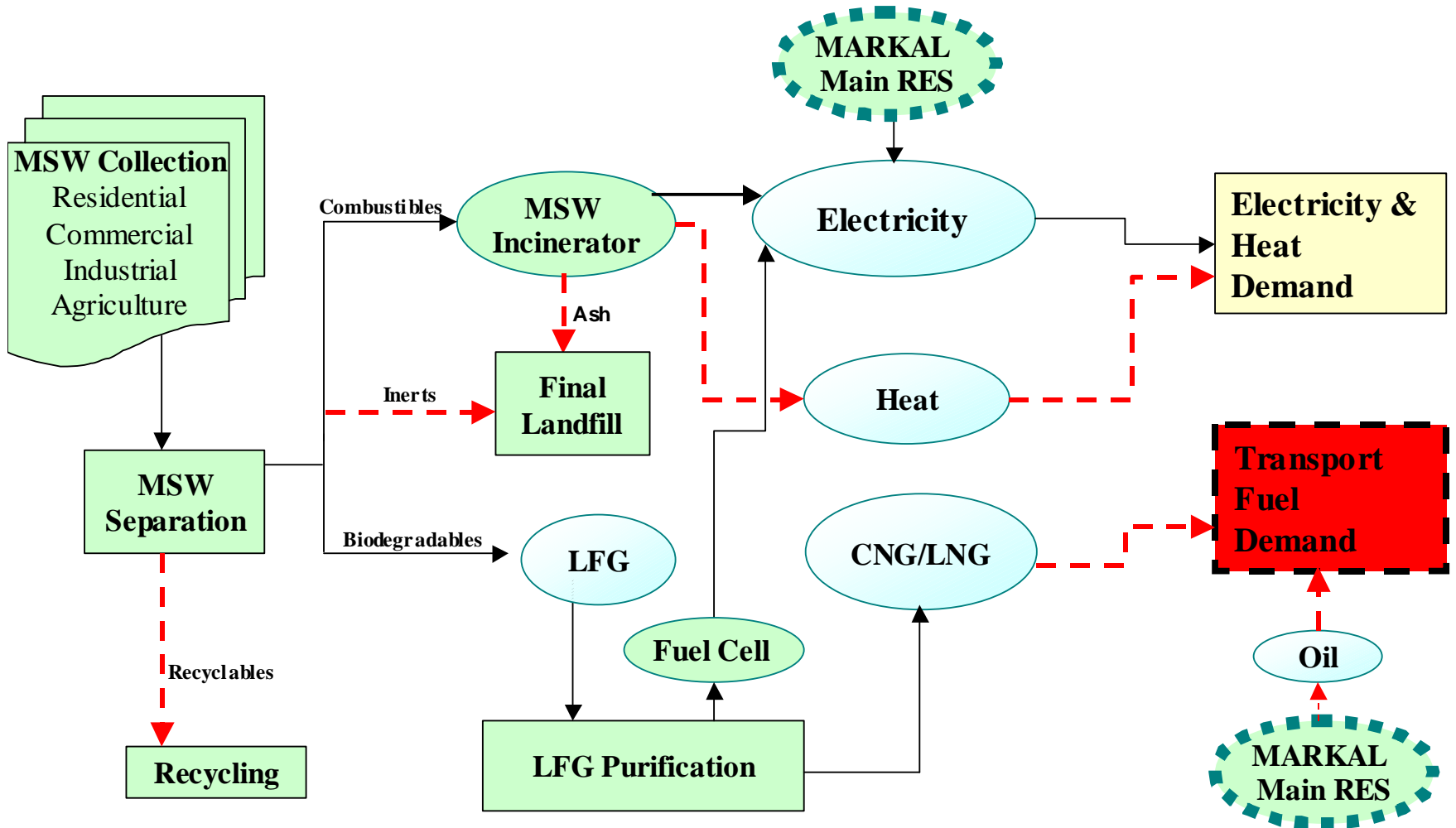

# Waste Water Modeling

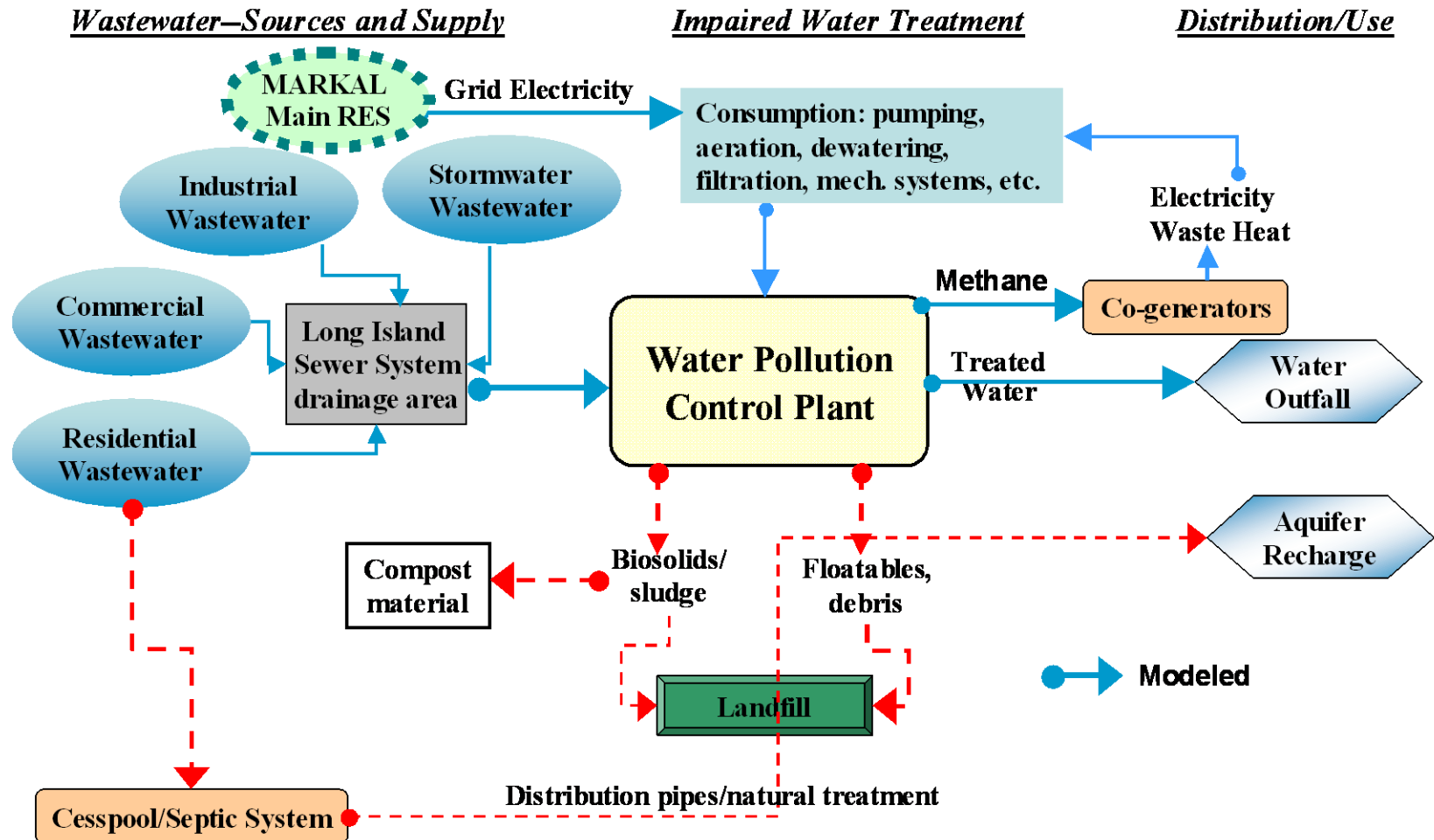

# Selected Results for Long Island

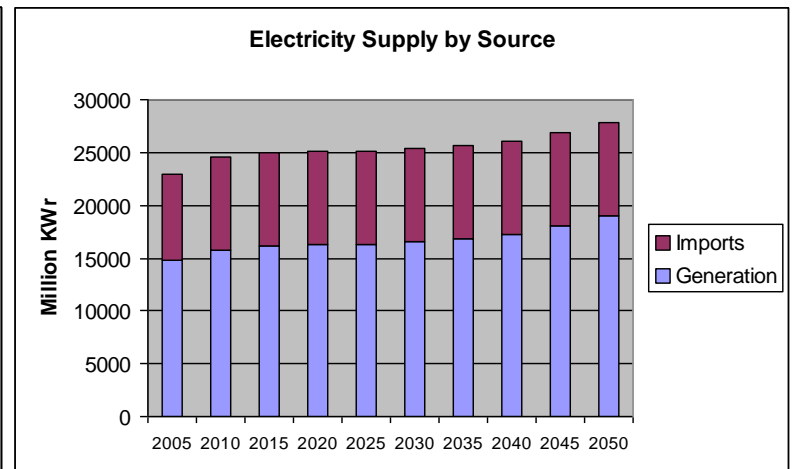
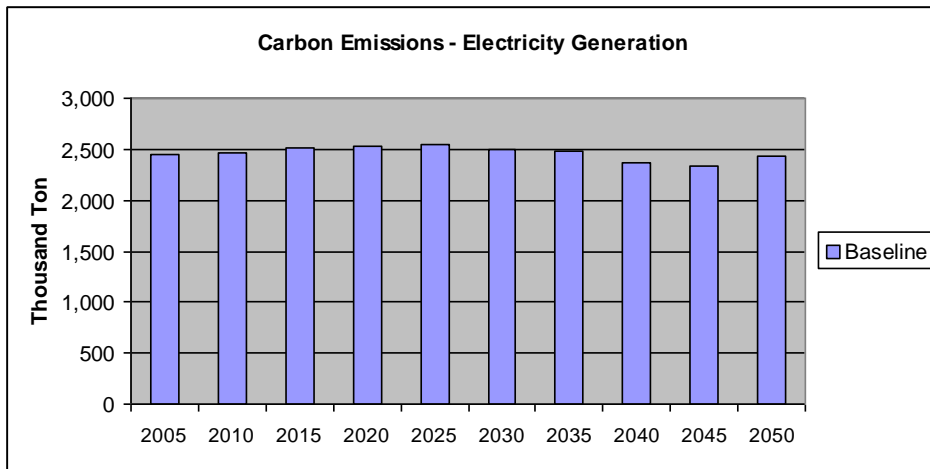
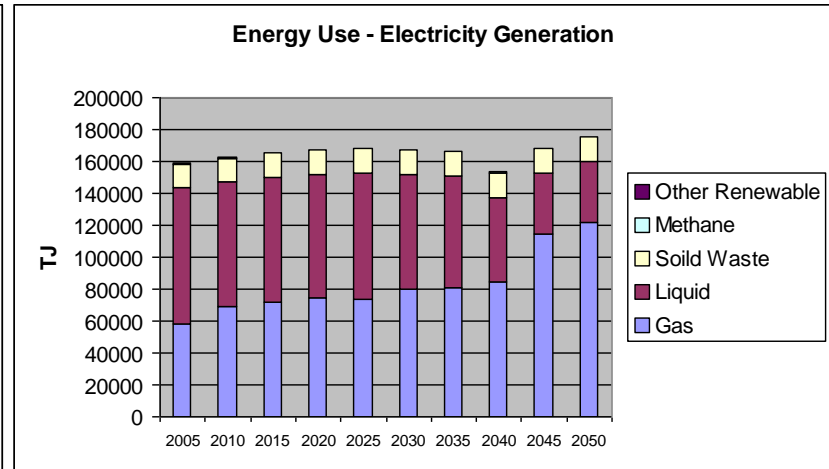
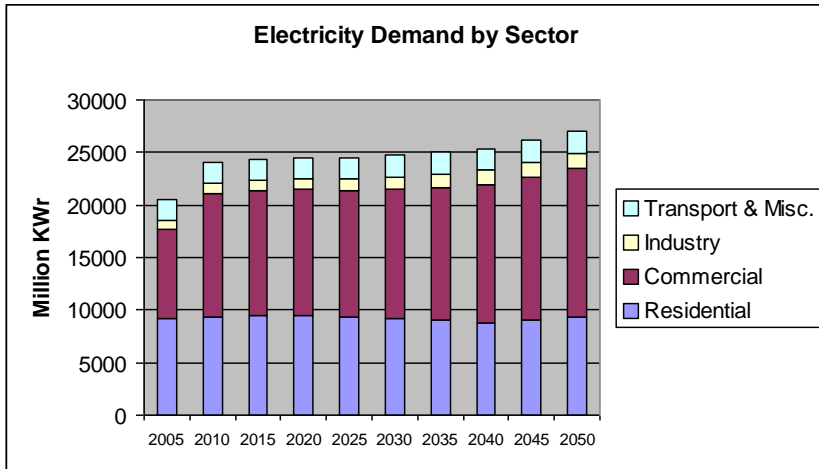

# Stakeholders for LI MARKAL

---

- ❑ Nassau and Suffolk County Governments
- ❑ Long Island Regional Planning Board
- ❑ Long Island Power Authority/National Grid
- ❑ New York Metropolitan Transportation Council
- ❑ LI 2035 Study Team
- ❑ EPA Region II (SIPs, TMDL, NEPA Section 309)
- ❑ Interstate Environmental Commission
- ❑ Metropolitan Transportation Authority/Long Island Rail Road

# Future Case Study for LI MARKAL

---

## **Applying Industrial Ecology Principles for the Long Island Railroad**

- ❑ Long Island has substantial concerns with solid waste disposal and energy demands with limited infrastructure
- ❑ Recently completed LI MARKAL can address upstream and downstream elements of the waste management integrated with energy and water systems
- ❑ MARKAL can provide the transparency and the transferability needed to accelerate and possibly leap frog advanced waste management practices and technologies towards improved industrial ecology

# Integrated Long Island MARKAL Model for Energy Security & Environmental Sustainability

## Energy, Water and Solid Waste Systems Analysis



## Questions?

Vatsal Bhatt ([vbhatt@bnl.gov](mailto:vbhatt@bnl.gov))

John Lee ([jcl@bnl.gov](mailto:jcl@bnl.gov))

Edward Linky ([Linky.Edward@epamail.epa.gov](mailto:Linky.Edward@epamail.epa.gov))

